

FireMixer-14

Temperature-Controlled Cooker-Mixer System



PRODUCT SPECIFICATIONS

Dimensions	31.2" width x 30.9" height x 22.4" depth
Body	Brushed stainless steel
Voltage	208-240VAC
Electrical	1-Phase / 50/60Hz / 15.5 Amps
Capacity	Up to 40 lbs / 18.1 kg batches (recipe dependent) 5 gallons at brim capacity
Product Temperature	Up to 350° Fahrenheit
Weight of Unit	160 lbs
Certifications	ETL Listed for Safety and Sanitation
Warranty	1 year limited product warranty

FAST AND EASY CANDYMAKER

The FireMixer-14 is a high-precision and automatic tabletop confectionery cooker-mixer. As Savage Bros developed this product with the artisan confectioners and entrepreneurs in mind, the FireMixer-14 has built-in features that make it fast and easy to operate, monitor, and control production.

This product is the ideal machine for crafting countless confections such as caramel, gummies, fudge, toffee, brittle, and more! FireMixer-14 is suitable for smaller batches and R&D lab production.

KEY FEATURES

- 1 Easy one person operation
- 2 Automatic product mixing
- 3 All stainless-steel construction for longevity
- 4 Advanced touch screen control
- 5 Precision cooking with separate product and kettle temperature control
- 6 Removeable agitator for easy cleaning
- 7 Tilting kettle
- 8 Water-flush cooling



OPTIONAL

ACCESSORIES

- Universal Depositor Table Stand
- Cream Can Assembly
- Splash-Lid Open Center
- Nut-Stirrer Agitator 2-Blade
- Mobile Base on Casters
- Draw Off Sanitary Valve

**DIMENSIONAL
DRAWINGS**

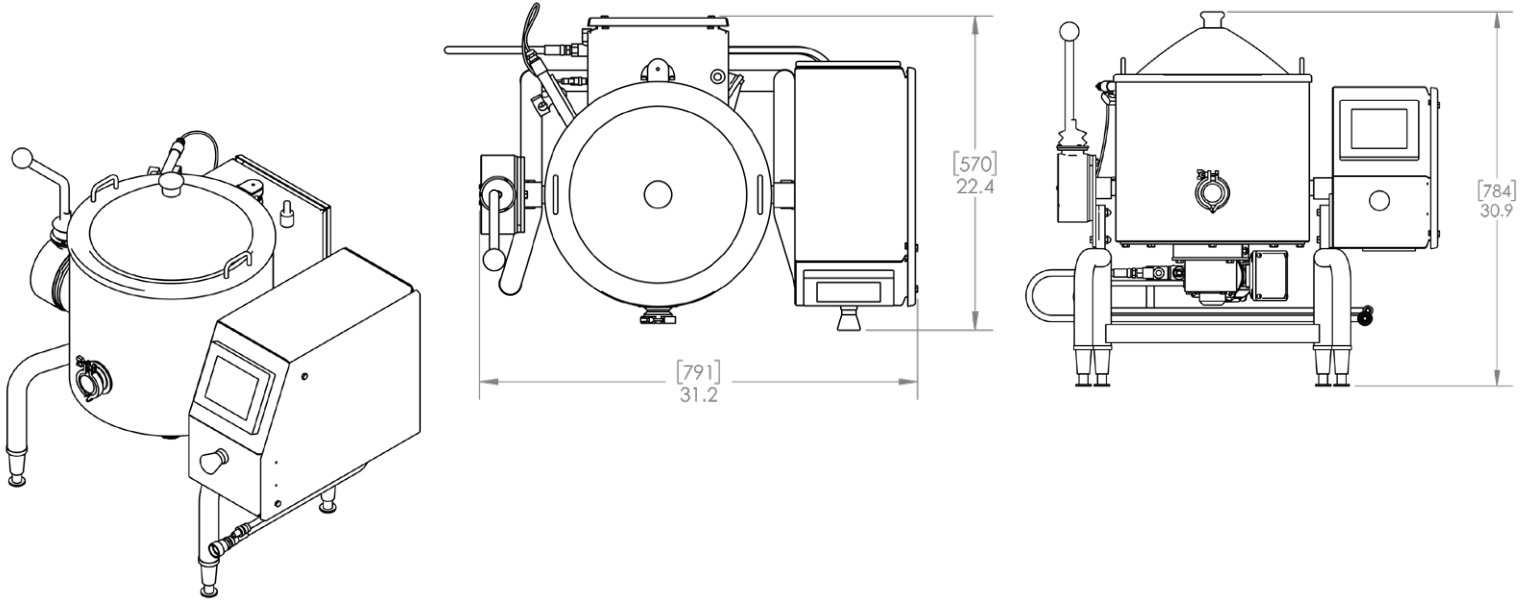

ACCESSORIES: Not included in the FireMixer-14 Pricing

OPTIONAL ADD-ONS



Universal Depositor Table Stand



Cream Can Assembly



Splash lid



Nut-Stirrer Agitator 2-Blade



Mobile Base



Draw Off Sanitary Valve