

FireMixer-14

Temperature-Controlled Cooker-Mixer System



TOTAL COOKING CONTROL FOR HIGH-VOLUME FOODSERVICE KITCHENS

The FireMixer-14 is a high-precision, automatic tabletop cooker-mixer designed for busy, fast-paced, versatile kitchens producing a wide variety of menu items.

With high-heat performance, automated hands-free mixing, and precise temperature control, chefs can manage the entire cooking process for both culinary and confectionery creations with accuracy and repeatable results.

KEY FEATURES

- 1 Easy one person operation
- 2 Automatic product mixing
- 3 All stainless-steel construction for longevity
- 4 Advanced touch screen control
- 5 Precision cooking with separate product and kettle temperature control
- 6 Removeable agitator for easy cleaning
- 7 Tilting kettle
- 8 Water-flush cooling

PRODUCT SPECIFICATIONS

Dimensions	31.2" width x 30.9" height x 22.4" depth
Body	Brushed stainless steel
Voltage	208-240VAC
Electrical	1-Phase / 50/60Hz / 15.5 Amps
Capacity	Up to 40 lbs / 18.1 kg batches (recipe dependent) 5 gallons at brim capacity / 18 quarts batches
Product Temperature	Up to 350° Fahrenheit
Weight of Unit	160 lbs
Certifications	ETL Listed for Safety and Sanitation
Warranty	1 year limited product warranty

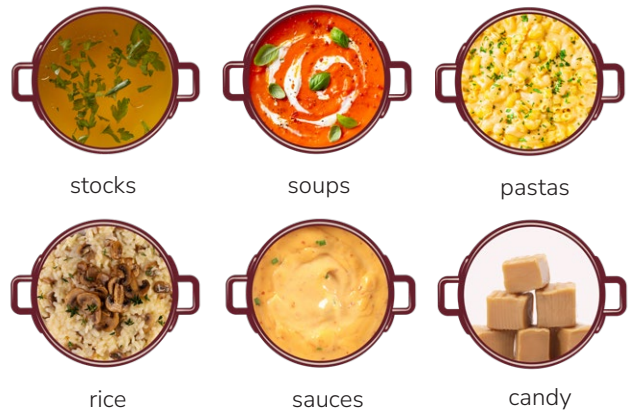

OPTIONAL ACCESSORIES

- Universal Depositor Table Stand
- Cream Can Assembly
- Splash-Lid Open Center
- Nut-Stirrer Agitator 2-Blade
- Mobile Base on Casters
- Standard Valve
- Ball Valve

DIMENSIONAL DRAWINGS

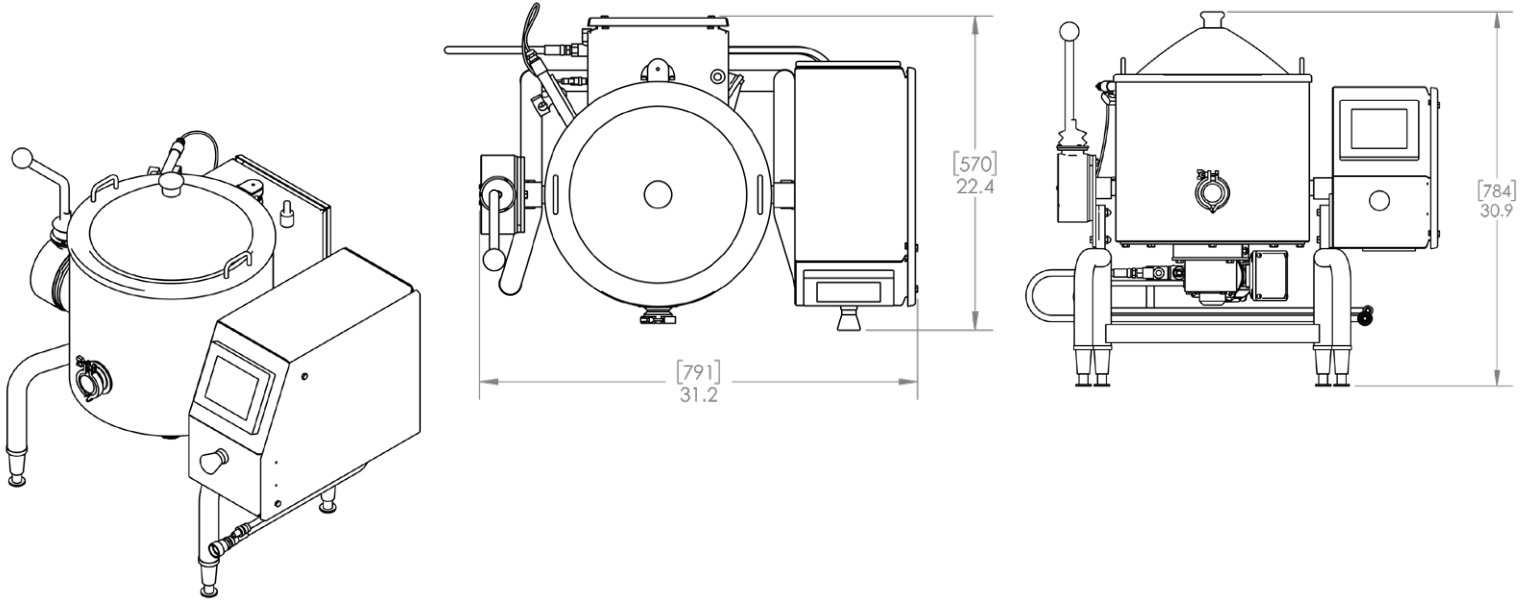

ACCESSORIES: Not included in the FireMixer-14 Pricing

OPTIONAL ADD-ONS



Universal Depositor Table Stand



Cream Can Assembly



Splash lid



Nut-Stirrer Agitator 2-Blade



Mobile Base



Standard Valve



Ball Valve